



Sole registered supplier of Pace products in New Zealand

PAGE[®]



TT-65

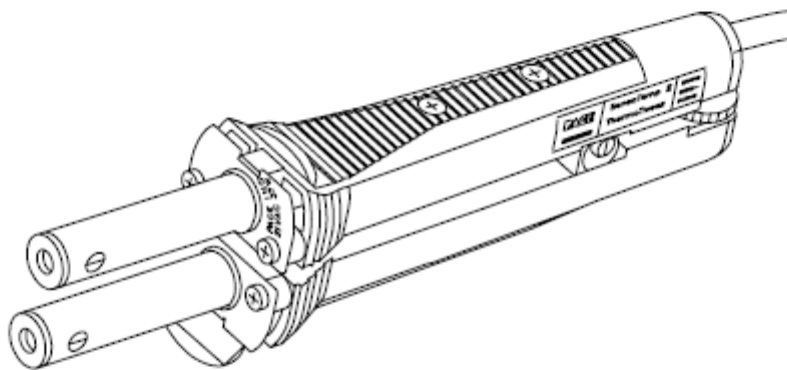

TT-65 ThermoTweez Handpiece

Operation & Maintenance Instructions



Sole registered supplier of Pace products in New Zealand

TT-65

TT-65 ThermoTweez Handpiece

Part Number 7025-0001

Manual Number 5050-0336

Rev. C

TT-65

These instructions detail the basic operational guidelines for using the TT-65 ThermoTweez handpiece.

INTRODUCTION

The ThermoTweez handpiece provides safe, one-handed removal of a wide variety of "J" Leaded (PLCC), Leadless (LCCC), SOICs, PQFPs, Bumper Packs (BQFPs), large extended lead (FlatPacks), SMT Connectors and Chip style components in a matter of seconds. The ThermoTweez's low temperature, high capacity heating can remove even the largest components quickly and easily. The ThermoTweez is a member of the PACE SensaTemp family of advanced SMT/Thru-Hole soldering/desoldering handpieces and works with any PACE SensaTemp power source.

CAUTION

Always use this handpiece in a well ventilated area. A fume extraction system such as the PACE Arm-Evac is highly recommended to help protect personnel from solder flux fumes.

NOTE

Remember that the ThermoTweez is primarily a component removal tool. Also, a ThermoTweez Cushion Grip Kit (PACE P/N 6993-0155) is available for applications where the handpiece is under continuous use at high tip temperature settings. This kit provides added comfort to the user.

TT-65

TIP & TOOL STAND SETUP

If you have purchased a TT-65 handpiece with a Tip & Tool Stand, set up the Tip & Tool Stand in the following manner.

1. Place 4 Rubber Feet on the bottom corners of the enclosed Tip & Tool Stand.

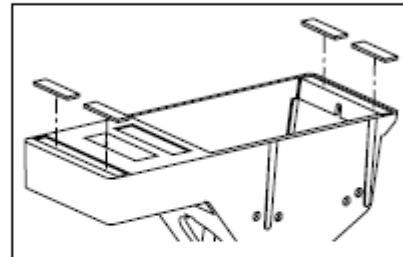

2. Position the enclosed Bracket onto the Tip & Tool Stand as shown. Secure in position using the 2 Mounting Screws supplied.

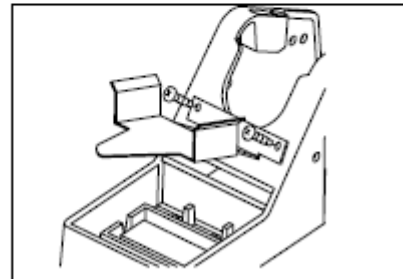

3. Install the Drip Tray and secure with Mounting Screw.

4. The SX-80 Tip & Tool Stand can be attached to some PACE power sources. Refer to the power source Operation & Maintenance manual for the applicable instructions.

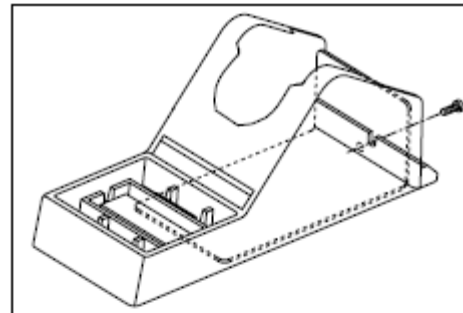

5. Place the sponge in the Tip & Tool Stand using the following procedure.

- a) Remove the 2 small punched out center portions of the sponge & place into the sponge well of the stand in the position shown.
- b) Place the large sponge section into the sponge well as shown.
- c) Dampen the sponges with water.

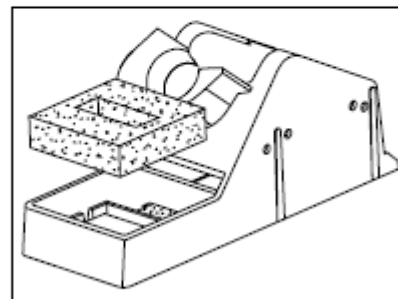

5. Place the handpiece into its Tip & Tool Stand.

TT-65

HANDPIECE SETUP

HANDPIECE ALIGNMENT

Check the handpiece heaters for proper alignment with each other. Proper handpiece (and tip) alignment is essential for effective operation.

1. Remove any installed tip halves.
2. **With the handpiece at room temperature**, adjust the Heaters parallel to each other (see ②) using the Tip Gap Adjustment Thumb Screw (item ①). If the heater ends are even with each other, go to "Power Source Connection". If the ends are not even, go to step 3.
3. Loosen the handpiece Hinge Screw (item ③) 1/2 turn.
4. Holding the handpiece in a vertical position (heaters facing down), place the ends of the two Heaters against a hard flat surface to insure proper alignment. The Heater ends should be even with each other and flush against the flat surface. Gently push the rear of the handpiece handles to force both Heaters against the flat surface.
5. Retighten Hinge Screw (item ③) to secure in position.

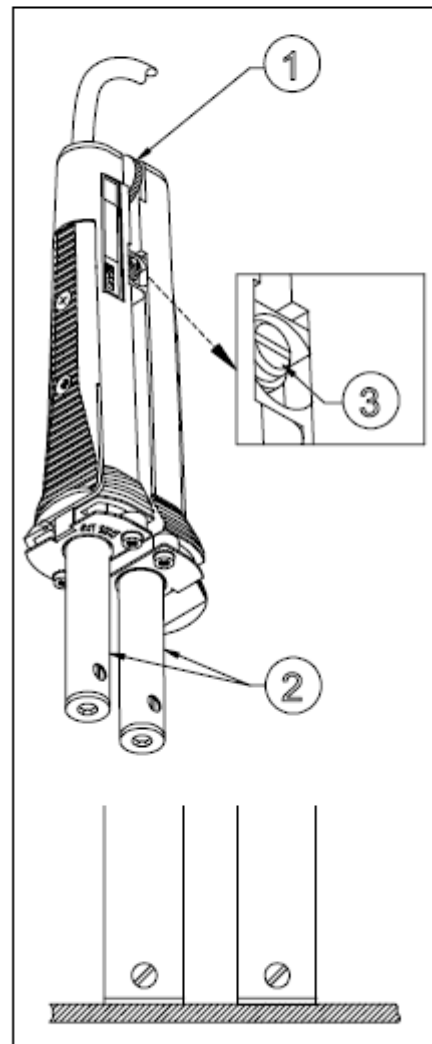

TT-65

POWER SOURCE CONNECTION

Connect the handpiece connector plug into one of the Power Receptacles on your PACE power source in the following manner.

1. Align guide on connector with slot on power receptacle.
2. Insert connector into power receptacle.
3. Turn the connector housing clockwise to lock in place.

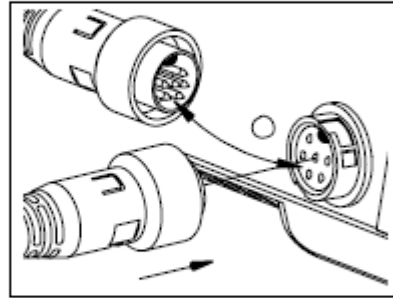

NOTE

If using your ThermoTweez for the first time or if you have just replaced the heater, we recommend that you follow the "Heater Burn-in" procedure (Red tag on handpiece) to increase the life expectancy of the heater.

TIP TEMPERATURE

The TT-65 efficiently transfers heat by contact and typically allows component removal at relatively low temperatures in the 288 - 343°C (550 - 650°F) range. Tip temperature and removal times will vary with each application. PACE recommends the use of a 316°C (600°F) tip temperature setting for initial use in any particular application. With practice, many components can be removed at lower temperatures. Use the lowest possible tip temperature that will provide rapid, yet controlled solder reflow. Lower temperatures extend tip and heater life, allow solder to remain on the lower surfaces of the tip (to improve thermal linkage between the tip and the component during component removal) and help prevent possible board damage.

Refer to the Tip & Temperature Selection System booklet for your particular handpiece/tip combination. For all Dial Display SensaTemp systems, the booklet will indicate the correct Dial Setting for the True Tip Temperature desired. On systems incorporating a Digital Readout, set the desired operating temperature and Tip Offset Constant for the TT-65 handpiece/tip combination into the channel powering the TT-65.

TT-65

TIP INSTALLATION

The following instructions are for tip installation only. If a tip is currently installed in the handpiece, remove the installed tip (heater hot) and clean the heater bore using the supplied 3/16" diameter wire brush prior to the installation of a new tip.

1. Tips should be installed when the heaters are hot. Turn your power source ON and set the temperature for the channel powering your handpiece to an appropriate temperature (315°C (600°F) is recommended for initial use). Place the handpiece in a ThermoTweez Hot Cubby (PACE P/N 6019-0035) when not in use.

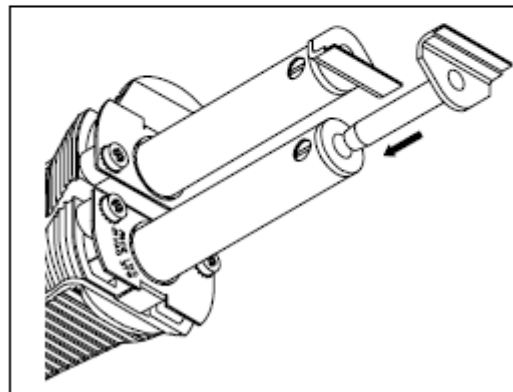

2. Select the proper tip for your application. Refer to Table I or the Tip & Temperature Selection System booklet.

NOTE Selection of the proper tips is essential for successful repair. If you do not have the proper tip, call PACE or your local authorized PACE distributor for assistance. Ask for a copy of the PACE Tip & Applications Catalog for the latest listing of available tips. Custom tips are available on request.

3. Each ThermoTweez tip consists of two identical halves. With the handpiece at the desired temperature, hold the handpiece with the heater ends pointing up at an angle. Insert the shaft of one tip half fully into one of the ThermoTweez handpiece heaters. Insert the shaft of the second tip half fully into the other heater.

NOTE If you like, the heater set screws may be tightened very slightly to hold the tip halves in position while they are being aligned.

4. There are three basic methods for aligning your tips in the ThermoTweez handpiece depending on tip size and type. Tips should be above solder melt temperature prior to performing the alignment procedure. Follow the appropriate procedure (a, b, or c) to install and align the ThermoTweez tip properly.

TT-65

a) Small PLCC Tips (no slots) and Chip Component Tips:

1. Position the tip ends as shown.
2. Squeeze the handpiece closed to press the tip ends together.
3. Holding the handpiece closed, adjust the tip ends as necessary so that they meet precisely together.
4. Gently tighten the heater set screws to secure the tip halves in position.

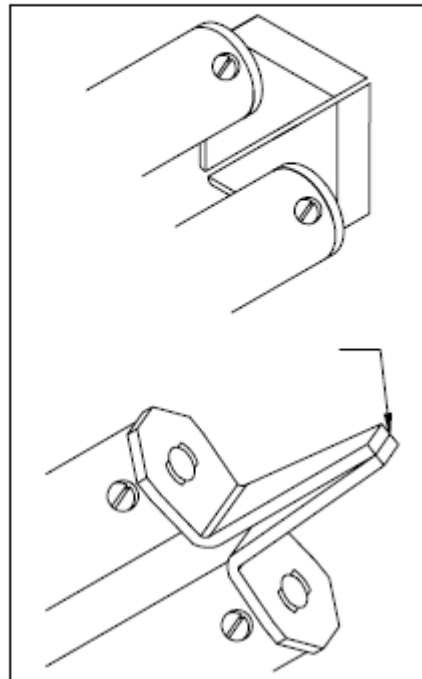

b) Large PLCC Tips (with slots): Large PLCC tips (PLCC 44 lead count or higher) have a small slot cut into the diagonal edge of each halve.

1. With the tip halves oriented as shown, insert the supplied Tip Alignment Tool (item ①) between the two tip halves and position the Alignment Blocks (item ②) of the tool into the tip Slots (item ③) as shown.
2. Squeeze the handpiece closed to grip the Tip Alignment Tool (item ①) tightly between the two tip halves.
3. Tighten the heater set screw on each heater using the tip tool or a small blade screwdriver to secure tip into position.

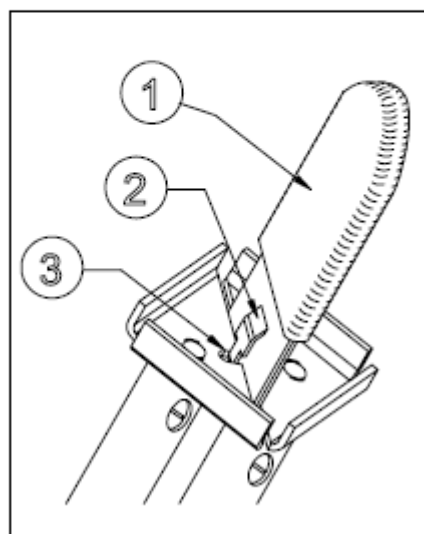

TT-65

c) SOIC, SOJ/SIMMS Tips & Surface Mount Connector Tips:

1. Position the tip halves as shown.
2. Using the tip gap adjustment thumb screw at the rear of the ThermoTweez handpiece, increase the space between the tip halves to allow insertion of the Sponge Tool or Fiber Tool from the Tip Maintenance Station (PACE P/N 6993-0138).

NOTE

The Tip Tool may also be used for this purpose.

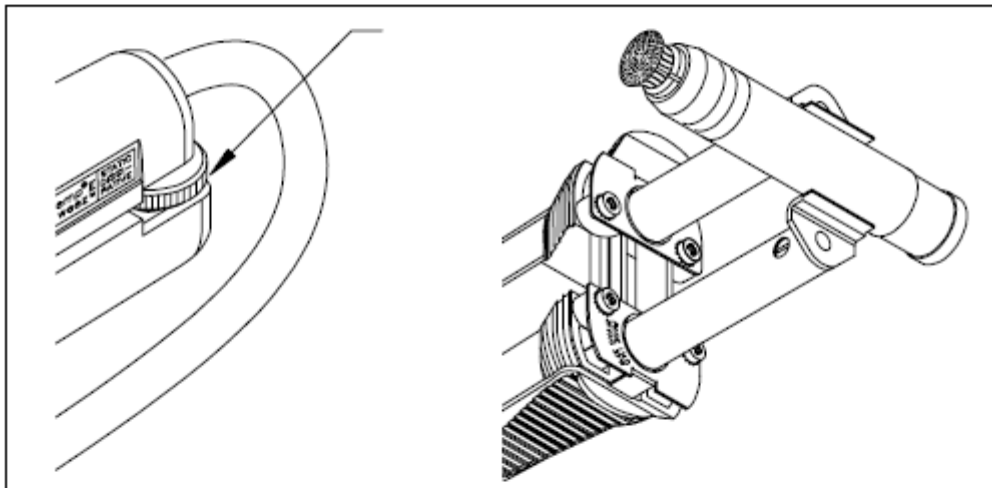

3. Position the Sponge Tool or Fiber Tool between the tip halves as shown.
4. Squeeze the handpiece closed with the tip ends pressed firmly against the Sponge Tool or Fiber Tool.
5. Gently tighten the heater set screw on each heater using the tip tool or a small blade screwdriver to secure tip into position.

TT-65

TIP PREPARATION

Always follow the procedure below for each component removal operation and prior to storage of the handpiece in the hot cubby. Proper preparation will insure optimum results and increase tip life.

NOTE

The use of a PACE Tip Maintenance Station (P/N 6993-0138) is recommended for the proper preparation and maintenance of all ThermoTweez tips. If this item has not been purchased, contact your local authorized PACE distributor for assistance.

1. Insure that the installed tip has reached the set tip temperature.
2. Use the fiber tool found in the Tip Maintenance Station to remove all solder dross and excess solder from the inside edges of the tip. PACE recommends placement of the tip over the moistened sponge area of the Tip Maintenance Station to catch solder and dross removed from the tip.
3. Wipe the inside edges of the tip using the sponge cleaning tool or the sponge area of the Tip Maintenance Station.

NOTE

Insure that the sponge material is moist.

4. Use a large gauge solder to tin each of the tip lower inside edges.

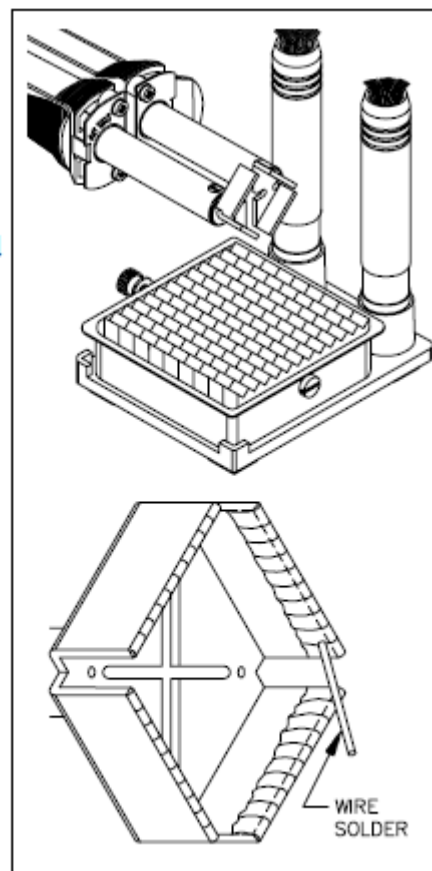

Sole registered supplier of Pace products in New Zealand

TT-65

SPECIAL APPLICATIONS

If you require assistance in the use of this handpiece or require assistance with a special application, contact PACE Applications Support at:

Telephone: 1-888-(535)-7223 (toll-free) or (301) 490-9860

Fax: (301) 604-8782

CORRECTIVE MAINTENANCE

Use Table 1 and the illustrations to determine the cause of malfunctions to your ThermoTweez handpiece. Disconnect the handpiece from the power source; use a voltmeter to check resistance across the handpiece Connector Plug pins as outlined in the Heater Assembly Checkout Procedure.

CAUTION

The handpiece must be at room temperature when performing the Checkout Procedure to prevent potential burns to the technician. Additionally, all readings have been determined from the cold handpiece.

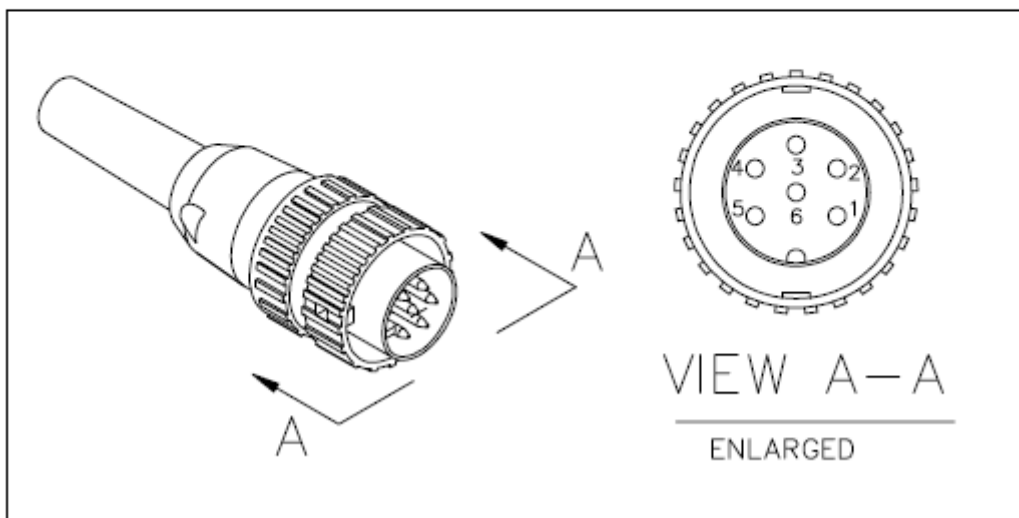

TT-65

SYMPTOM	CHECKOUT PROCEDURE	CAUSE	SOLUTION
No heat on either heater.	Check resistance - Pin 3 to Pin 6. Resistance should be 110 ohms. If circuit reads open - -	Open Sensor	Replace Heater Assembly "A".
	Check resistance - Pin 2 to Pin 5. Resistance should be 6 ohms. If circuit reads open - -	Open Heater	Replace both Heater Assemblies.
Handpiece overheating.	Check resistance - Pin 3 to Pin 6. Resistance should be 110 ohms. If circuit reads less than 105 ohms - -	Shorted Sensor	Replace Heater Assembly "A".
Heat on only 1 heater.	Check resistance - Pin 2 to Pin 5. If resistance equals 12 ohms - -	Open Heater	Replace cold Heater Assembly.
Fuse blows when unit is turned on.	Check resistance - Pin 4 to Pin 5 and Pin 4 to Pin 2. Circuit should read open. If not - -	Shorted Heater	Remove handpiece side cover "B". Disconnect wire connections to Heater "B". Check resistance again. If circuit reads open, replace Heater "B". If circuit is not open, replace Heater "A".

Table 1. Heater Assembly Checkout Procedures

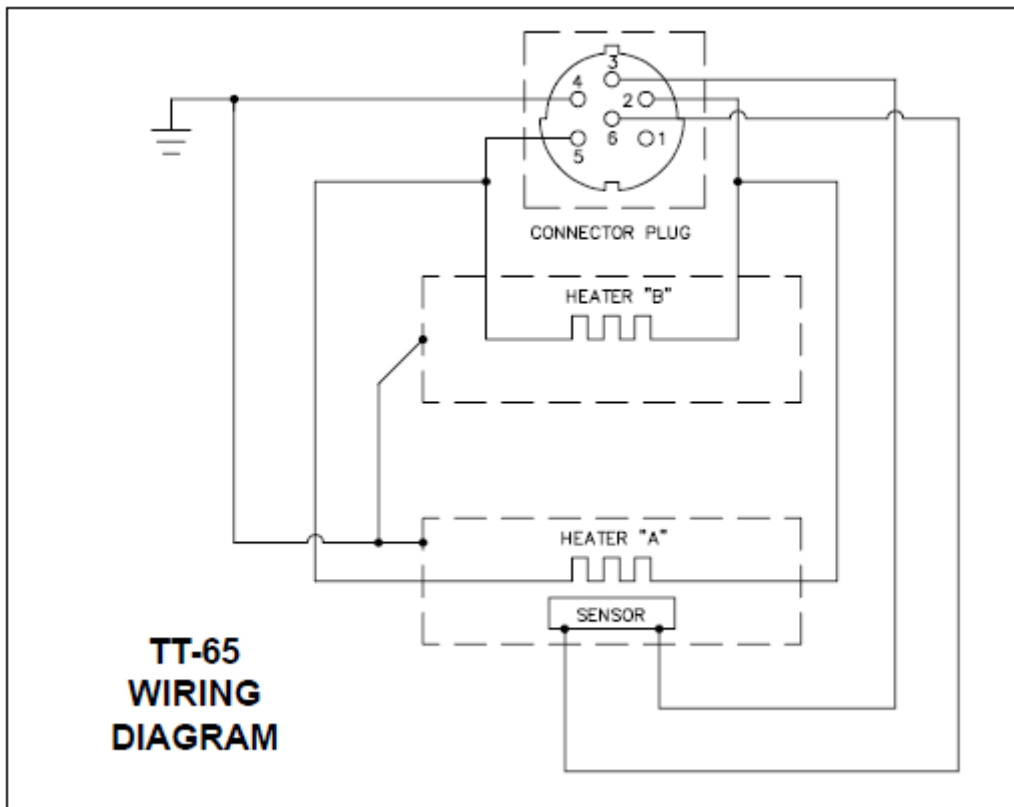

TT-65

REPLACEMENT PARTS

Table 2 lists the parts needed to maintain your ThermoTweez handpiece.

Description	Part Number
Heater Assembly "A" (with sensor)	6010-0082-P
Heater Assembly "B" (without sensor)	6010-0083-P
Heater Set Screw	1348-0547
Tip Tool	1100-0206
Tip Alignment Tool	1100-0234
Cushion Grip Kit	6993-0155
Replacement Pads For Cushion Grips	1317-0029-P
Tip Redi-Rak	6021-0007-P
3/16 inch O.D. Wire Brush For Cleaning	1127-0014-P
Tip Maintenance Station	6993-0138

Table 2. Replacement Parts

Sole registered supplier of Pace products in New Zealand

TT-65

PACE Incorporated retains the right to make changes to specifications contained herein at any time, without notice.

Contact your local authorized PACE Distributor or PACE Incorporated to obtain the latest specifications.

The following are registered trademarks and/or servicemarks of PACE Incorporated, Laurel Maryland U.S.A. and may only be used to identify genuine PACE products or services:

Arm-Evac, Cir-Kit, ConducTweez, CRAFT, Flo-D-Sodr, Heat Wave, HotSpot, LapFlo, MBT, Micro Portable, MicroChine, MiniChine, Mini-Wave, PACE, Pacenter, Pik-Tip, PETS, Prep-Set, ResistTweez, SensaTemp, Snap-Vac, Sodr-Pen, Sodr-X-Tractor, ST, StripTweez, Thermo-Drive, ThermoFlo, ThermoJet, ThermoPart, ThermoPik, ThermoTweez.

The following are trademarks and/or servicemarks of PACE Incorporated, Laurel Maryland U.S.A. and may only be used to identify genuine PACE products or services:

Sodrtek, Toolnet.



Since 1958, PACE Incorporated has provided advanced technology training in all aspects of hand soldering, rework and repair.

For any questions regarding this Operation & Maintenance Manual, contact your local authorized PACE distributor or contact PACE directly at the appropriate address listed below.

PACE Inc. 9893 Brewers Court, Laurel, Maryland 20723-1990
Tel. (888) 535-7223 (toll-free), (301) 490-9860
FAX 301 483 7030

PACE Europe Ltd. Sherbourne House Sherbourne Drive Tilbrook
Milton Keynes Buckinghamshire England MK7 8HX
Tel. (44) 01908 277 666 FAX (44) 01908 277 777

© 1999 PACE Incorporated, Laurel MD. All rights reserved. Printed in the U.S.A.